

Developing Curriculums and Educational  
Subjects Center



General Directory for  
Developing the Subject of  
Computer & Information  
Technology

# Information and Communication Technology

## The programming Projects



**Student Book**  
**Third Secondary**  
**Unit Two**

**2016/2017**



# Information and communication Technology

## The Programming Projects

### Third Secondary

#### Second Term – Student Book

Prepared by

**Dr.Taher Abdelhamid Eladly**

Computer and Information Technology  
Curricula Expert and Head of Department  
Centre For Curriculum &Instructional Materials  
Development

**Eng. Wassim Salah Eldeen El**

**Manzalawy**  
Department Director  
General Administration for Computer &  
Information Technology Development

**Mr. Tamer Abdelmohsen Mansour**

Department Director  
General Administration for Computer &  
Information Technology Development

**Mr. Ahmed El Anasari ElSalamoni**

Department Director  
General Administration for Computer &  
Information Technology Development

Educationally revised by

**Dr.Rougina Mohamad Hegazy**

Expert in Centre For Curriculum & Instructional Materials Development

Technically revised by

**Ms Mashaallah Mohamad Mohammad**

Computer and Information Technology Curricula Expert Computer

**Prof. Mohamad Fahmi Tolba**

Computer and Information Technology Prof

Ain Shams University



## Designed by

**Ms Abeer Mohamad Anwar Mohamad**

**Department Director**

General Administration for Computer & Information Technology development

## Translated by

**Amira Fawzy Ahmed**

Head of Foreign Languages Department  
Centre for Curriculum & Instructional  
Materials Development

**Dalia Hassen Mohamed Mahmoud**

Educational specialist of English language  
Office of the development of the English language  
material director

## Technical Terms

**Dr Amany Korany Ibrahim**

**General Manager**

General Administration for Computer and Information Technology Development

**Eng. Wassim Salah Eldeen El Manzalawy**

**Department Director**

General Administration for Computer & Information Technology Development

## Introduction

This book presents a comprehensive vision of the relationship between science, technology and society, which reflects the role of information and communication technology and its innovations in various fields of life and community development, through training students on the skill of the implementation of some software projects based on the Markup language HTML, programming languages PHP &VB.NET and applications such as Expression Web.

Those projects help students practice many of the technological skills and conscious behaviors by using information and communication technology, in addition to the development of their multi positive attitudes.

The first unit of the book deals with implementation of a project to convert a number between the numerical systems programmatically, and this unit includes a simplified explanation of numerical systems as a cognitive basic background, followed by display the unit topics that represent the stages of implementation of the project, and the implied skills that the students have to train on.

The second unit deals with the Logic Gates which is considered the basics for the electronic integrated circuits and it represents the basics for the computer and electronic devices, and how it performs through applied projects production which stimulate it, with showing some life applications to employ the idea of Logic Gates, by considering life decisions as a set of issues or mathematical formulas which can be evaluated and judged right or wrong , which is considered a lifestyle and style of thinking which helps in taking life decisions in a scientific method, which represents a very important input to qualify you, dear student, for your future life, and qualification towards the specialized study in this field.

**GOD GRANTS SUCCESS**

**STAFF**

## Table of contents

Subjects	page number
Unit two: Producing a project of the logic gates simulation	6
First subject: The logic AND gate	10
Second subject: Producing a project of the logic gate simulation AND by using visual basic.net	19
Third subject: Producing a project of the logic AND gate simulation by using PHP Enrichment only for the academic year 15 _ 16	32
Forth subject: The logic OR gate	40
Fifth subject: Producing a project of the logic OR gate simulation	48
Sixth subject: Producing a project of the logic gate OR simulation by PHP language Enrichment only for the academic year 15 _ 16	60
Sevens subject: The logic NOT gate	65
Eighth subject: Producing a project of the logic NOT gate simulation.....61	71
Ninth subject: Producing a project of the logic NOT gate simulation.by PHP language..... Enrichment only for the academic year 15 _ 16	78
Tenth subject: Employing the logic gates in taking life decisions	82

## **Aims of INFORMATION & COMMUNICATION TECHNOLOGY book for Third–grade general secondary:**

- ❖ Acquiring some basic concepts and processes for computer systems and information and communication technology basics.
- ❖ Taking into account certain aspects of Intellectual Security (human, moral and social life) that are concerned with the use of Information & Communication Technology.
- ❖ Using the technological production tools (Visual Basic .Net & PHP.....) in supporting and developing education.
- ❖ Producing work and projects that is relatively creative by using technological processes, programs and tools.
- ❖ Employing technological communication tools in communication, interaction, cooperation and exchange of content and insights with others, in order to support learning.
- ❖ Using technological (tools and resources) in data processing, evaluating and reporting the results.

# Unit two

Producing a project of the logic gates simulation

**By the end of the unit students will be able to:**

- 1- Recognize some scientific concepts and terminology related to the computer (Programming Languages - The logic gates AND-OR-NOT).
- 2- Suggest simple projects for the logic gates simulation (AND&OR&NOT).
- 3- Employ information and communication technology applications in the construction of his educational content and development of its tasks.
- 4- Practice programming skills PHP&VB.NET in performing his tasks.
- 5- Follow the ethics and behaviors of respect for copyrights when dealing with information, devices, networks, services and web applications.
- 6- Employ interactive learning environments in his learning.
- 7- Employ the logic gates to solve some life and educational problems.
- 8- Use the information and electronic data in the performance of research and educational tasks in partnership with his classmates.
- 9- Employ the technological tools and resources in supporting making life decisions.

# The logic gates

## Introduction

Dear students, after the implementation of a project of a program to convert a number between the numerical systems, we start together to implement several projects to produce software to simulate some of the logic gates ,which requires you to be aware of some of the concepts and knowledge which is considered its cognitive base.

This unit deals with the concept of Logic (gates and circuits) and their kinds, and their related applications and uses in our daily lives, and how it can be produced. These subjects reflect the role of the logic gates in taking many decisions .and especially daily life decisions.

The concept of "logic" refers to the correct thinking rules which we follow to judge right or wrong issues or mathematical formulas.

In addition, the logic gates are the entry point for university study specialized in this field.



**Before dealing with subjects of this unit, we should recognize the following:**

The idea of the work of a lot of electronic devices depends on the use of logic circuits to perform the basic processes that are performed in a frequently, accurately and very high speed aspect.

## The Logic Circuit

The logic circuits consist of a number of components which are called logic gates; **the logic gate** is a simple electronic circuit that has one INPUT or more and only one OUTPUT.

Based on the availability of certain conditions in the inputs, the value of the output is determined, and thus it can be considered as it implements a logical process.

There are many Logic gates which is differ in its function according to its design.

Some of these famous logic gates are:

<b>(1)</b>	<b>(2)</b>	<b>(3)</b>	<b>(4)</b>	<b>(5)</b>	<b>(6)</b>	<b>(7)</b>
<b>AND</b>	<b>OR</b>	<b>NOT</b>	<b>NAND</b>	<b>NOR</b>	<b>XOR</b>	<b>XNOR</b>

The three gates (AND, OR, NOT) are considered the basic types of the logic gates, which are used in designing a lot of other gates types.

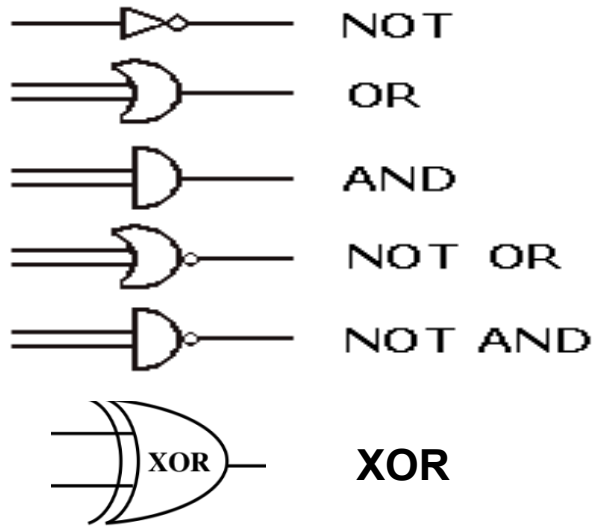

### **First Subject** **The logic AND gate**



### **Learning outcomes**

**At the end of this subject, learner should have the ability to:**

- Explain the logic AND gate.
- Discuss the compatibility gate symbol with his classmates.
- Design possibilities table of the effect of the two input switches state on the output.
- Explain The Truth Table of AND gate.

## The logic AND gate

It is called the compatibility gate, it is a gate that has two inputs or more, and only one output. AND gate is represented electrically, by two switches or more, (A , B) that are connected respectively, each of the two switches is considered an input of the logic AND gate's inputs, thus, the two switches represent (Two Binary Variables), as, the light (L) stands for the output, as it is represented on the following diagram :

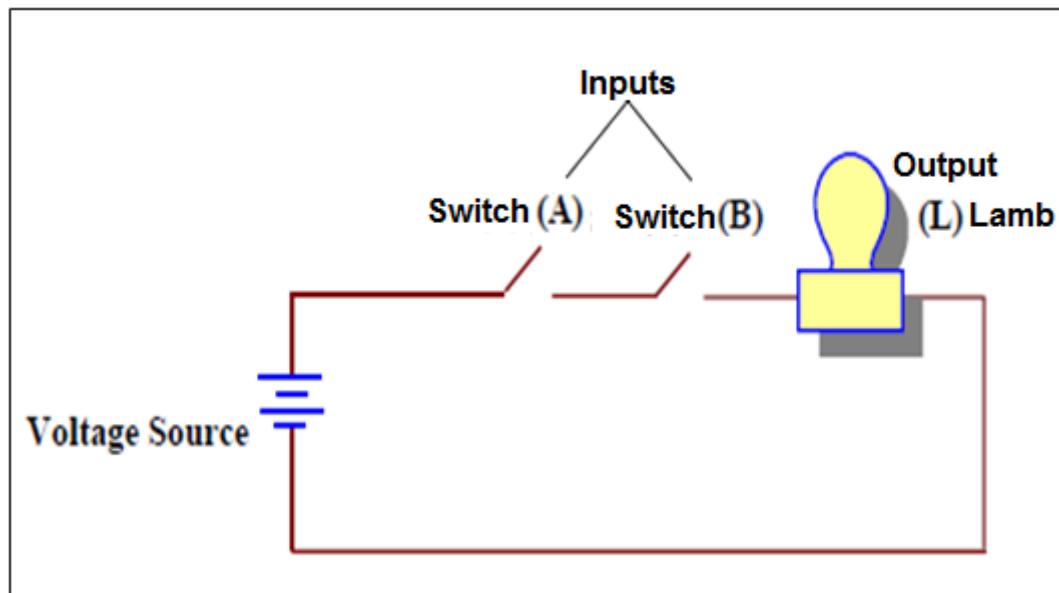

(The simulated figure of the compatibility gate AND)

Study the previous figure, describe it, try to conclude the relation of its components, and then discuss the results you reached with your teacher and classmates.

From the previous figure, we can conclude the following:

- By connecting the two switches, the circle is closed, which represents an input that has (1) value by the (Two Binary System).

- By disconnecting any switch, the circle is opened, so, this represents an input that has (0) value by the (Two Binary System), i.e. the value of any switch that leads to opening the circle is equivalent to (0).
- Lighted light means that the output value equivalent (1).
- The non-lighted light means that the output value equivalent (0).

### Practice (1)

"The circuit that is equivalent to the logic AND gate"

Activity book (p: 5)

The question now is:

What are the possibilities of the two switches state (A, B) and their effect on the electric light (L) state?



Discuss with your classmates and your teacher the results you get, and match it with the following diagram:

<b>A</b>	<b>B</b>	<b>L</b>
<b>OFF</b>	<b>OFF</b>	<b>NON - LIGHTED</b>
<b>OFF</b>	<b>ON</b>	<b>NON - LIGHTED</b>
<b>ON</b>	<b>OFF</b>	<b>NON - LIGHTED</b>
<b>ON</b>	<b>ON</b>	<b>LIGHTED</b>

Table (1) The possibilities of the two switches state (A, B) and their effect on the electric light (L) state.

### The logic AND gate symbol

The following symbol represents the logic AND gate that has two binary inputs, study the code, describe it, and then, discuss with your classmates and your teacher.

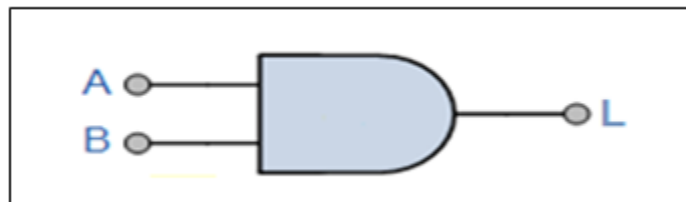

**AND gate symbol (two binary inputs)**

By studying the logic AND gate symbol, it is cleared

that:

- (A, B) refer to the inputs of AND gate, and (L) refers to the output of the gate.
- The gate's input that is on the left side of the symbol includes the value of all the input possibilities, as it expresses the input as (two binary numbers) (0,1), on the other hand, the output is on the right side (binary numbers) also.

### Number of forms (possibilities)

Each of the logic gates has a number of forms or possibilities that is accounted by knowing the number of inputs of the logic gate by the following law:  **$N = 2^n$**

As, N refers to number of forms, the (2) number refers to the binary system base, that we use as a value of the gate's input (0,1), and (n) refers to the number of the gate's input.

For example: AND gate (two binary inputs), its forms number is:

$$N = 2^2 = 4$$

If the AND gate has triple inputs, its number of forms or possibilities are:

$$N = 2^3 = 8$$

On the same pattern, you can calculate the number of forms or possibilities of any logic gate.

### The Truth Table

It is a table which helps in explanation of the logic gate behavior, taking into account, the relation between the input and the output of the Logic gate.



The Logic AND gate has only output equal (1) in the state of participating each of the two inputs in the same value (1), and this means two conditions must be implemented in two binary input gate, to get an output that has (1) value, and that is what you can notice in the electric representation which is equivalent to the compatibility gate AND ,as the light (L) is lighted only when the two switches (A,B) are connected together and became in (on) state.

From the previous, we can conclude the truth table of the two binary inputs logic AND gate, as its input is expressed by a binary value (0, 1) as the following:

Symbol	Truth Table		
<p>2-input AND Gate</p>	B	A	L
	0	0	0
	0	1	0
	1	0	0
	1	1	1

The truth table of the two binary inputs logic AND gate

From the previous Truth table, it is noticed that:

By considering that any input is a condition, if the two conditions (1) are achieved in the logic AND gate, it leads to getting the output.

The output in AND gate= (1) just when all the inputs equal the value (1).

### Practice (2)

Forms (possibilities) of the output of the logic AND gate and the truth table

Activity book (p: 6)

### The Boolean formula of the logic AND gate

The Boolean algebra is considered a formula of logistic that shows how logic gates work. The Boolean expression is a brief method in order to show what is happening in any logic circuit, the following Boolean expression represents the AND gate that has two inputs and it is expressed with two formulas :

$$\mathbf{Y = A . B} \quad \mathbf{Or} \quad \mathbf{Y = AB}$$

This is called “Logical Multiplication”, We can express it as the following:

The output Y is equal to A AND B

We can summarize what is mentioned before in the following table:

Statement	Representation on the AND gate																		
The gate's name	<b>AND</b>																		
The logic symbol - standard- of the gate																			
The number of forms	<p>We can calculate the number of possibilities that forms the truth table of the gate of the two binary inputs by the following law:</p> $\mathbf{N = 2^n \quad \rightarrow \quad N = 2^2 = 4}$																		
The truth table	<table border="1" style="margin-left: auto; margin-right: auto;"> <thead> <tr> <th colspan="3">Truth Table</th> </tr> <tr> <th>B</th> <th>A</th> <th>L</th> </tr> </thead> <tbody> <tr> <td>0</td> <td>0</td> <td>0</td> </tr> <tr> <td>0</td> <td>1</td> <td>0</td> </tr> <tr> <td>1</td> <td>0</td> <td>0</td> </tr> <tr> <td>1</td> <td>1</td> <td>1</td> </tr> </tbody> </table>	Truth Table			B	A	L	0	0	0	0	1	0	1	0	0	1	1	1
Truth Table																			
B	A	L																	
0	0	0																	
0	1	0																	
1	0	0																	
1	1	1																	
The Boolean formula of the gate	<p><math>\mathbf{Y = A \cdot B \quad \text{OR} \quad Y = AB}</math></p> <p>An Expression of the Boolean formula of the gate AND that has two inputs.</p>																		

Table (2) the AND gate summary

## **Second Subject**

### **Producing a project of the logic AND gate simulation**

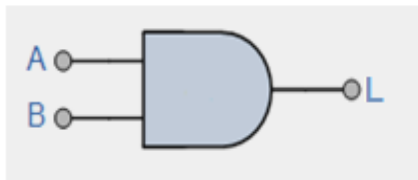

### **Learning outcomes:**

**By the end of this subject learner should have the ability to:**

1. Determine the stages of producing a project of the logic AND gate simulation by using the Visual Studio.Net application.
2. Design the interface of the project of the logic AND gate simulation.
3. Use the Visual Studio.Net application to build up the interface of the project, explaining the controls.
4. Explain the used programming code in the project of the logic AND gate simulation.
5. Employ the code of the project implementation practically.

### The project purpose

Producing a program to simulate the logic AND gate.

### The project production requirements:

- 1- The scientific background of the logic gate AND, and that is what is studied before.
- 2- Determination of the programming language that you can use in the project production, you can make use of what is previously studied and employ your experience and your skills in Visual Basic.Net and PHP languages.

### Implementation of the project procedures:

- 1- Designing the interface that the user uses for the project "Graphic User Interface" GUI, and determining the suitable controls for each use of the project implementation in a suitable aspect.
- 2- Adjusting controls' properties in view of the necessary needs of the project production.
- 3- Writing the programming code.

## The stages of the project production:

### Firstly: The designing stage

Dear student, you can design the interface of the project that is based on your desires, and include controls on it, to achieve your aim of simulating the (connect/disconnect) switch of turning on the electric light process.

The following figure is a proposal of designing the form window and its necessary controls to produce the project.

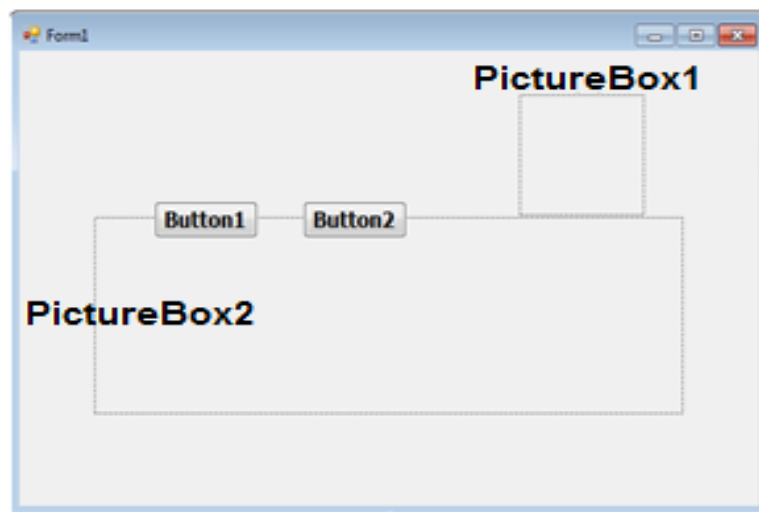

**By studying the components and the elements of the previous form, we can conclude controls on the form window and the aim of each of them, and it is obviously shown in the following table:**

Control	Its purpose
Form 1	The basic object on which we put all the used controls on the user's interface.
Button1	An object that is used to implement specific code when it is clicked.
Button2	An object that is used to implement another code when it is clicked.
PictureBox1	An object that is used in showing the picture of the (lighted-non-lighted) light.
PictureBox2	An object that is used in showing the picture of the electric circuit.

## Practice (1)

### Designing the user interface of the project

Activity book (p: 8)

Secondly: Stage of implementing the design and adjust the controls properties of the project.

You can start to insert the needed controls for producing a project of simulation of running the logic gate "AND" by opening the Visual Studio.Net application, and inserting controls on the form window and adjust its properties, in order to be prepared to write necessary code to employ them.

## Activity (1)

"Designing the user's interface implementation by using (Visual Studio. Net) application"

Activity book (p: 9)

(The procedures from 1:3)

### Thirdly: Writing the programming code stage:

Before starting writing the project code, try to suggest the possible results of the project code implementation according to the light state (the output), we can show its four possibilities in the following table:

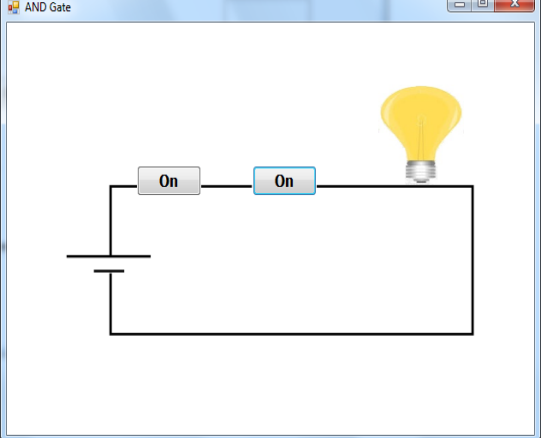
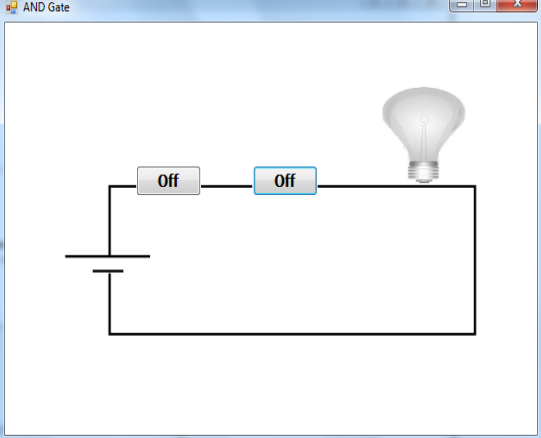
	
<ul style="list-style-type: none"> <li>-The first light state is: <b>On</b></li> <li>-The second light state is: <b>On</b></li> <li>-The light picture : lighted</li> </ul>	<ul style="list-style-type: none"> <li>-The first light state is: <b>Off</b></li> <li>-The second light state is: <b>Off</b></li> <li>-The light picture : non-lighted</li> </ul>



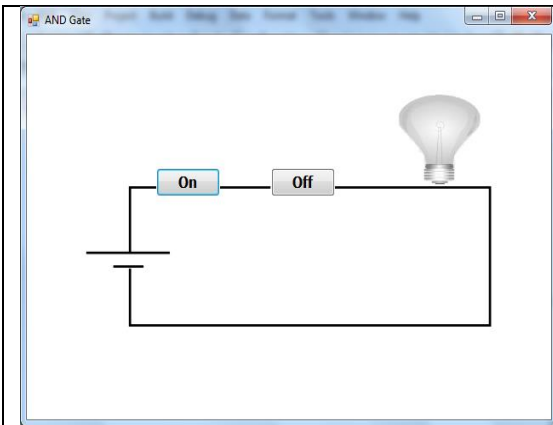

- The first light state is : **On**
- The second light state is : **Off**
- The light picture : non-lighted

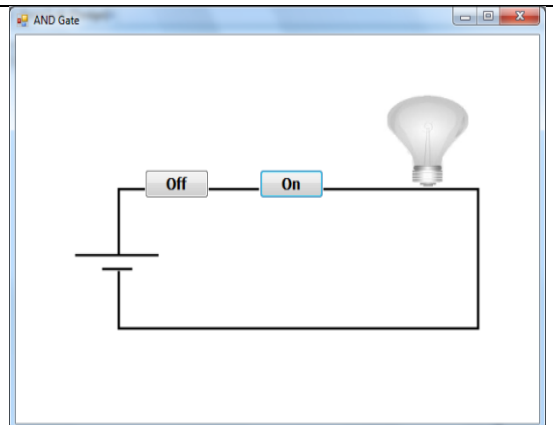

- The first light state is : **Off**
- The second light state is : **On**
- The light picture : non-lighted

### Observations:

#### The idea of code is summarized as follows:

Determining an object or more that is responsible for the code implementation when a certain event occurs on the object, and in the project, a code can be written in the following objects:

- ◀ The button state is changed between "On" and "Off" by pressing on Click.
- ◀ Finding two pictures in two different files of the light, one of them is lighted and the other is non-lighted, are shown in the same place of the PictureBox1 tool depending on the instructions of the programming

#### Form object (Form1\_load event):

- To show the non-lighted light image in picturebox1.
- To show the electrical circuit image in picturebox2.
- To show the two buttons in (Off) state.

#### Button1 object:

- By pressing click on it, the code tests the switch state and changes it between (on- off).
- Then, testing the first and second switches state, and changing the light image into the suitable correct state for the two power switches state.

### Button 2 Object:

- By pressing click on it, the code tests the switch state and changes it between (On– Off).
- Then, testing the first and second switches state, and changing the light image into the suitable correct state for the two switches state.

### Writing the specific code of each object from the previous three objects and this is through:

- A code you prepared.  
Or
- Searching the internet for a code that could do the mission and it can be altered or developed as your project requires.  
Or
- By using a ready function that is afforded by the programming language which you use.

In a project of operating the logic gate AND simulation, we will study and explain the used code through the specific code of the book, its effect appears on the light state , whether it is lighted or non–lighted, according to the two switches state “On or Off” after pressing Click on the two switches.

Dear student, you can study and explain the next code, it is divided into three parts to facilitate its study:

```
Private Sub Form1_Load(ByVal sender As Object, ByVal e As System.EventArgs) Handles Me.Load
```

```
    Me.PictureBox1.Image = Image.FromFile("off.jpg")
```

```
    Me.PictureBox2.Image = Image.FromFile("andcircuit.jpg")
```

```
    Me.Button1.Text = "Off"
```

```
    Me.Button2.Text = "Off"
```

```
End Sub
```

First part

```
Private Sub Button1_Click(ByVal sender As System.Object, ByVal e As System.EventArgs) Handles Button1.Click
```

```
    If Me.Button1.Text = "Off" Then
```

```
        Me.Button1.Text = "On"
```

```
        If Me.Button2.Text = "On" Then
```

```
            Me.PictureBox1.Image = Image.FromFile("on.jpg")
```

```
        End If
```

```
    Else
```

```
        Me.Button1.Text = "Off"
```

```
        Me.PictureBox1.Image = Image.FromFile("off.jpg")
```

```
    End If
```

```
End Sub
```

Second part

```
Private Sub Button2_Click(ByVal sender As System.Object, ByVal e As System.EventArgs) Handles Button2.Click
```

```
    If Me.Button2.Text = "Off" Then
```

```
        Me.Button2.Text = "On"
```

```
        If Me.Button1.Text = "On" Then
```

```
            Me.PictureBox1.Image = Image.FromFile("on.jpg")
```

```
        End If
```

```
    Else
```

```
        Me.Button2.Text = "Off"
```

```
        Me.PictureBox1.Image = Image.FromFile("off.jpg")
```

```
    End If
```

```
End Sub
```

Third part

### Code explanation:

The first part:” setting the default state of the circuit “

```
Private Sub Form1_Load(ByVal sender As Object, ByVal e  
As System.EventArgs) Handles Me.Load  
    Me.PictureBox1.Image = Image.FromFile("off.jpg")  
    Me.PictureBox2.Image = Image.FromFile("andcircuit.jpg")  
    Me.Button1.Text = "Off"  
    Me.Button2.Text = "Off"  
End Sub
```

### Its purpose is:

Giving the role of the programming code to form1 in load event, to be implemented when loading the form window, where:

- The non-lighted light image is specified from “off.jpg” file to PictureBox1.
- The circuit image is specified from “circuit.Jpg” to PictureBox2.
- Showing button1 and button2 switches in off state.

### Notice that:

This code performs the same specific purpose of adjust the setting of object properties on the form window in design mode state, through the properties window, and you have the choice, but adjusting properties setting through the code has a

The second part:” Possibilities of operating the first switch “

```

Private Sub Button1_Click(ByVal sender As System.Object,
ByVal e As System.EventArgs) Handles Button1.Click
    If Me.Button1.Text = "Off" Then
        Me.Button1.Text = "On"
        If Me.Button2.Text = "On" Then
            Me.PictureBox1.Image = Image.FromFile("on.jpg")
        End If
    Else
        Me.Button1.Text = "Off"
        Me.PictureBox1.Image = Image.FromFile("off.jpg")
    End If
End Sub

```

**Notice that:** The second part of the code is divided into three divisions to facilitate its study.

## Explaining the code of each division in the second part:

1. The code is implemented in this stage when we click on button1.
2. Button1 switch is tested in off state, and its state is changed into on state, then the second switch state is tested; if it is also on "On" state the lighted light image is shown.
3. If the first switch is on "On" state its state is changed into "Off" and the non-lighted light image is shown.

## The third part: "Possibilities of operating the second switch".

```
Private Sub Button2_Click(ByVal sender As System.Object,  
ByVal e As System.EventArgs) Handles Button2.Click  
    If Me.Button2.Text = "Off" Then  
        Me.Button2.Text = "On"  
        If Me.Button1.Text = "On" Then  
            Me.PictureBox1.Image = Image.FromFile("on.jpg")  
        End If  
    Else  
        Me.Button2.Text = "Off"  
        Me.PictureBox1.Image = Image.FromFile("off.jpg")  
    End If  
End Sub
```

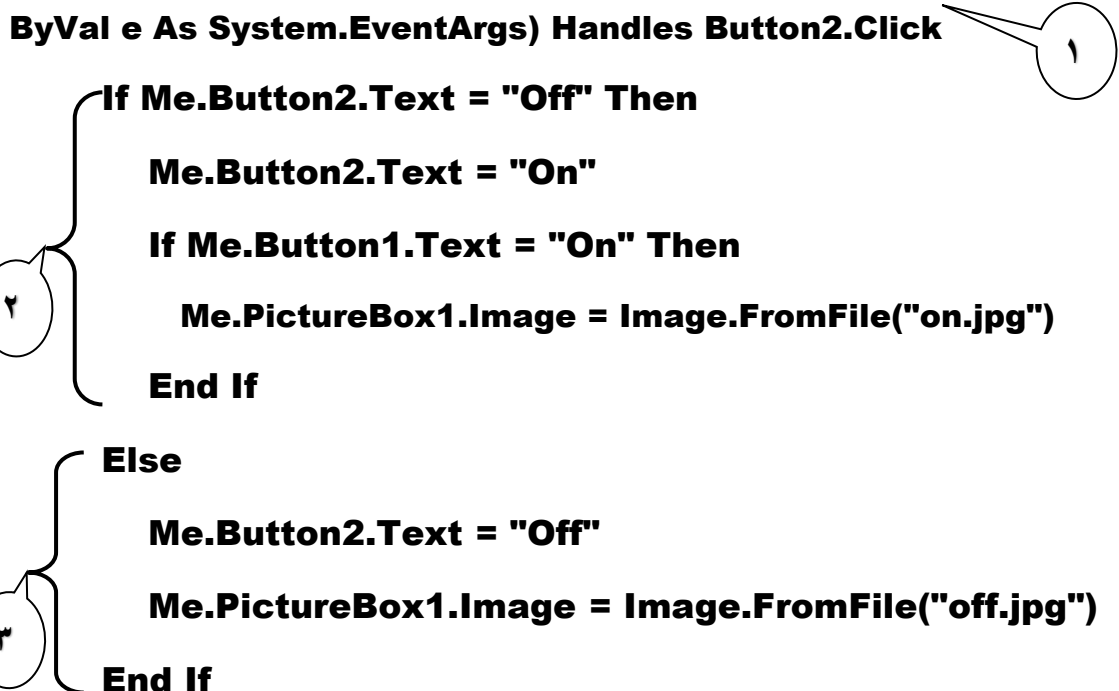

### Explaining the code of each section in the third part:

- (1) The code is implemented in this step when we click on Button 2.
- (2) Button 2 is tested in off state, we change its state into on, then we test the first switch state if it is on the lighted light image is also shown.
- (3) If the second switch is in on state, its state is changed into off, and the image of the non-lighted light is also shown.

## Activity (2)

Employing the code in production and  
implementation of the project of the logic gate  
"AND" simulation

STAGE (4)

Activity book (p: 11)



### Third Subject

Producing a project of the logic AND gate in PHP language



### Learning outcomes:

At the end of this subject, learner should have the ability to:

- Explain stages of producing a project of the logic gate AND in PHP language.
- Produce a project of the work of the logic gate AND simulation on the Internet browser screen in PHP language.
- Explain the code that is used in the Implementation of the project of the logic gate AND simulation.
- Employ the PHP code in producing the project practically.

### Requirements for the implementation of the project in PHP

#### language:

- (1) Implementation of the project through the Internet browser window based on some of the basics of markup language HTML, Expression Web application, and PHP language that previously studied.
- (2) Using Expression Web application to set up a static Web page in order to help you design the user's interface of the project and display it on the browser screen.

**Producing a project of the logic gate "AND" simulation in PHP language is going through the following stages:**

#### 1-Designing stage:

Dear Student you can design your Web page from your proposal contains the appropriate Controls to achieve the target of producing a project of the logic gate "AND" simulation to display it on the Internet browser screen.

#### 2-The implementation stage of the web page project:

Dear student, there are many applications that can be used in inserting controls on the browser window, like Expression Web application, as you can put necessary texts, titles and Controls to implement the design of the web page, through Control Tool Box.

The following figure shows the proposals of a Web page design that appears on the Internet browser window, and the implied Controls that are necessary for producing the project.

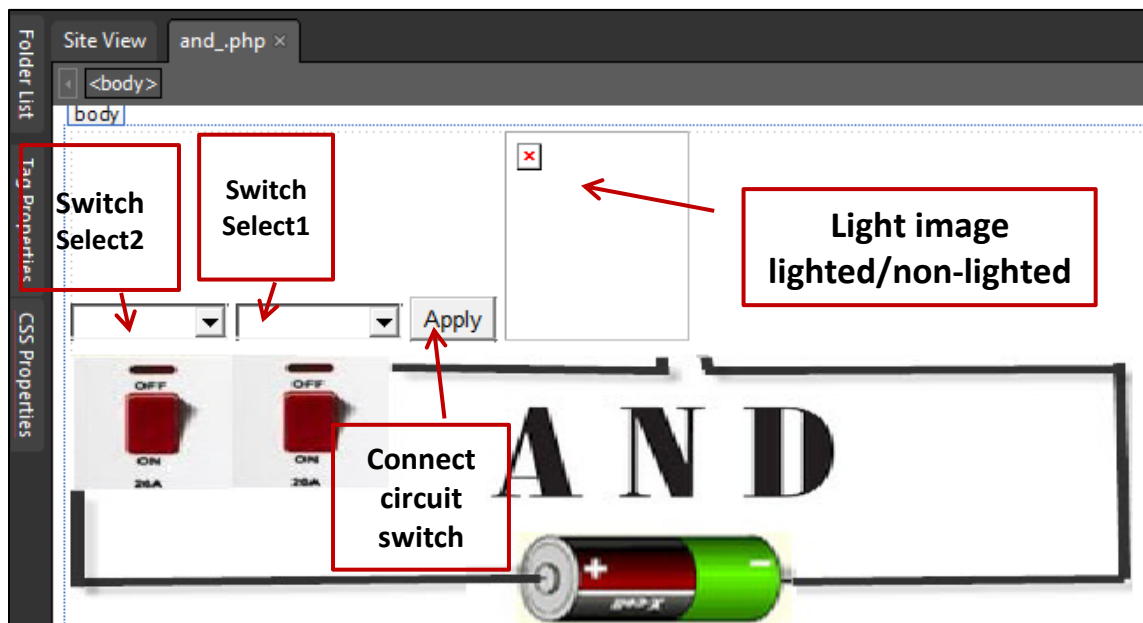

The position of select1 and select2 switches are selected from Drop-Down Box, by clicking on Apply, the image of the light is appeared whether it is lighted or non-lighted according to the state of the two switches together.

Study the previous image with your classmates and your teacher in the operating possibilities.

### 3- The stage of writing the code:

The following code appears by clicking "Split" during using Expression Web program.

```

<html>
  <head>
    <meta content="text/html; charset=utf-8" http-equiv="Content-Type" />
    <title> AND GATE </title>
  </head>
  <body>
    <form method="post" action=" ">
      <?php
        $lightstate="off.jpg";
        $choosekey1="off";
        $choosekey2="off";
        if(isset($_POST['Submit1']))
        {
          $choosekey1=$_POST['Select1'];
          $choosekey2=$_POST['Select2'];
          if ($choosekey1=="on" && $choosekey2=="on" )
            { $lightstate="on.jpg"; }
          else
            { $lightstate="off.jpg"; }
        }
      ?>
      <select name="Select1" style="width: 89px">
        <option> on </option>
        <option> off </option>
        <option selected= 'selected'> <?php echo $choosekey1; ?> </option>
      </select>
      <select name="Select2" style="width: 94px" >
        <option> on </option>
        <option> off </option>
        <option selected= 'selected'> <?php echo $choosekey2; ?>
        </option>
      </select>
      <input name="Submit1" type="submit" value="Apply" />
      <input name="Image1" type="image" height= "123" src="<?php echo $lightstate;
      ?>" width="105"/>
      <br /> 
    </form>
  </body>
</html>

```

1

2

3

4

## Explaining the code:

<u>Code no.</u>	<u>The Code</u>	<u>Function of the code</u>
1	<pre>&lt;?php     \$lightstate="off.jpg";     \$choosekey1="off";     \$choosekey2="off";     if(isset(\$_POST['Submit1']))     {         \$choosekey1=\$_POST['Select1'];         \$choosekey2=\$_POST['Select2'];     }     if (\$choosekey1=="on" &amp;&amp;     \$choosekey2=="on")     { \$lightstate="on.jpg"; }     else     { \$lightstate="off.jpg"; }     } ?&gt;</pre>	<p>The HTML code is completed with PHP code as it is in the code.</p> <p>We are dealing with the project through the next three variables :</p> <p><b><u>Slightstate variable:</u></b> The image of the light is allocated whether it is lighted or non-lighted according to the outcome of verifying the condition.</p> <p><b><u>Schooseskey1&amp; Schoosekey2 variables :</u></b> The values that have been selected are stored in these two variables.</p> <p><b>If (isset(\$_POST{'Submit1'}))</b> This sentence tests whether it is clicked on submit1 (apply) or not.</p> <p><b>If (\$choosekey1="on"&amp;&amp; \$choosekey2="on"</b> This sentence tests whether the value of the two variables together is "on" by using a logical link between the two conditions "&amp;&amp;".</p>

<u>Code No.</u>	<u>The Code</u>	<u>Function of the code</u>
2	<pre> &lt;select name="Select1" style="width: 89px"&gt;   &lt;option&gt; on &lt;/option&gt;   &lt;option&gt; off &lt;/option&gt;   &lt;option selected= 'selected'&gt;     &lt;?php echo \$choosekey1; ?&gt;   &lt;/option&gt; &lt;/select&gt;                     </pre>	<p>The code (Select): It is used to insert the first Drop-Down box, determine its name of property (name) and determine displaying Drop-Down width by the property Width.</p> <p>The code (Option): To determine the options to be displayed in the Drop-Down box.</p> <p>The code (php): <b>&lt;? Php echo \$chooseswitch1 ;?&gt;</b> To print a selection value \$chooseswitch1.</p>
3	<pre> &lt;select name="Select2" style="width: 94px" &gt;   &lt;option&gt; on &lt;/option&gt;   &lt;option&gt; off &lt;/option&gt;   &lt;option selected= 'selected'&gt;     &lt;?php echo \$choosekey2; ?&gt;   &lt;/option&gt; &lt;/select&gt;                     </pre>	<p>The code (Select): It is used to insert the second Drop-Down box, determine its name of property (name) and determine displaying Drop-Down width by the property Width.</p> <p>The code (Option): To determine the options to be displayed in the Drop-Down box.</p> <p>The code (php): <b>&lt;? php echo \$chooseswitch2 ;?&gt;</b> To print a selection value \$choosekey2.</p>

<u>Code No.</u>	<u>The Code</u>	<u>Function of the code</u>
4	<pre>&lt;input name="Submit1" type="submit" value="Apply" /&gt;</pre>	<p>-The code input: Its mission is to insert a button that has a name Submit1 by <u>name</u> property and determine the value <u>Apply</u> by <u>Value</u>.</p>
	<pre>&lt;input name="Image1" type="image" height= "123" src="&lt;?php echo \$lightstate; ?&gt;" width="105"/&gt;  &lt;img alt="" height="164" src="andconect1.jpg" width="604" /&gt;</pre>	<p>-The code input: To insert an object of image type, The source to get an image of the lighted light by the variable \$lightstate, in php statement.</p> <p>-The code img: Inserting the image of the battery on the browser screen, and determining the image resource by the file <u>andconect1.jpg</u>.</p>

## Possibilities of running the logic circuit AND on the internet browser window.

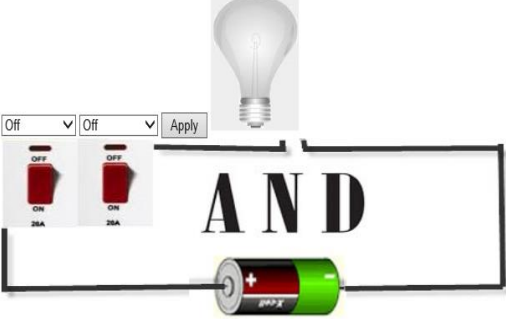
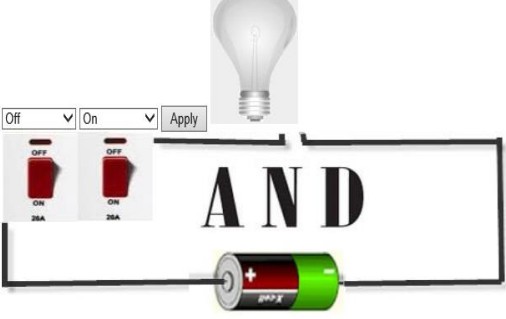
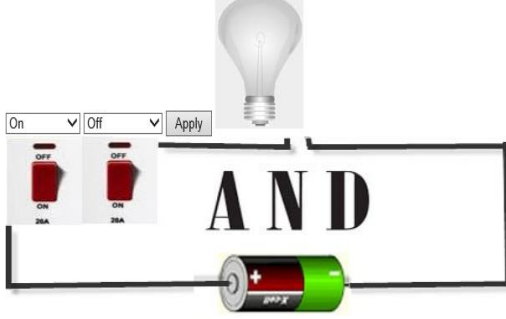
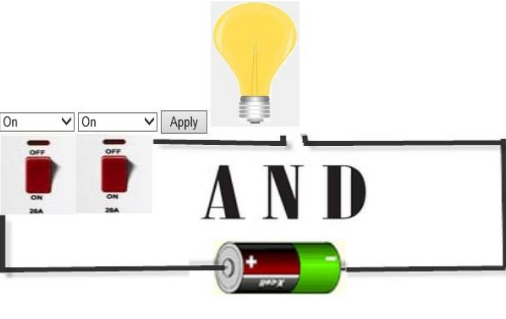
 <p>1- The two power switches are "off", the light is non-lighted</p>	 <p>2- One of the two power switches are "off", the light is non-lighted</p>
 <p>3- One of the two power switches are "off", the light is non-lighted</p>	 <p>4- The two power switches are "on", the light is lighted</p>

### Activity (1)

"Producing a project of logic AND gate simulation In PHP language on the web page."

Activity book (p: 13)



### **Forth Subject** **The Logic OR gate**



#### **Learning outcomes:**

**At the end of this subject learner should have the ability to:**

- Explain the work of the logic gate OR.
- Discuss the selecting gate code OR with his classmates.
- Explain Truth Table of OR gate.

## Logic OR gate:

It is called selecting gate, it has two inputs or more, and only one output, OR gate is represented electrically with two switches or more which are conducted together in parallel (A, B) as each of the two switches represents an input of the logic gate OR inputs, thus they represent (two binary inputs), while the light (L) represents the output as it is shown in the following equivalent figure of the selecting OR gate:

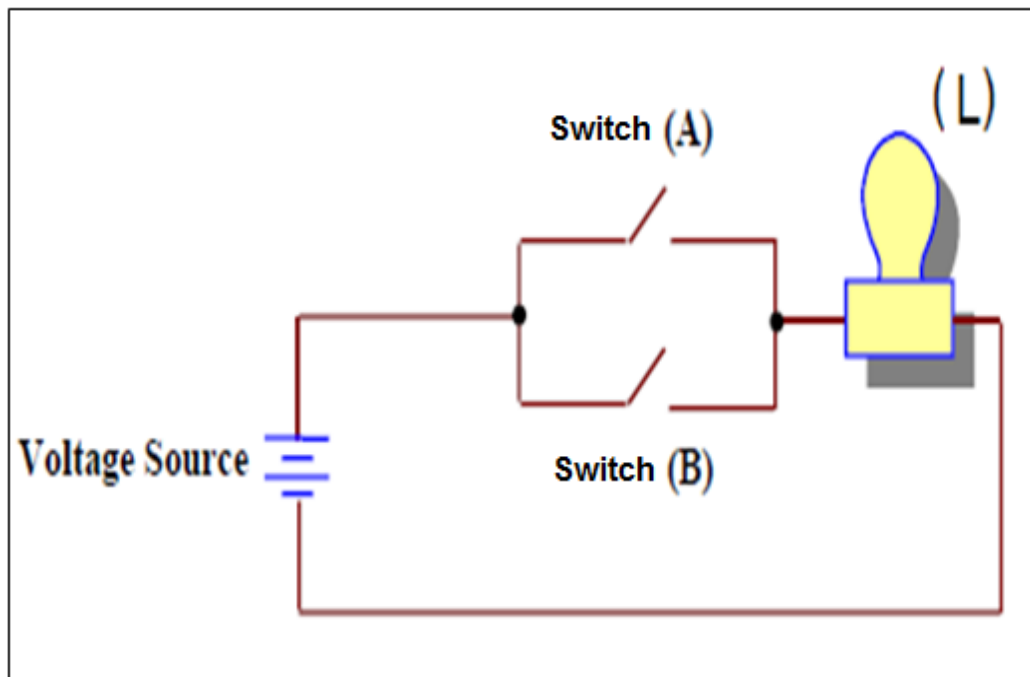

**(The equivalent figure of the selecting OR gate)**

**Study the previous figure; describe it, conclude the relation between its components, discuss this with your classmates and your teacher.**

**From the previous figure we can conclude the following:**

- The switch is connected to circuit "close the circuit", by clicking on the (on) switch, and it represents an input of (1) value in (two binary inputs), and which means that the value of any switch in (on) state equals (1).
- The lighted light means the output equals (1).
- Disconnect the switch "opening the circuit" represents an input of (0) value in the (two binary inputs), which means that the value of any switch in (off) state equals (0).
- The non-lighted light means the circuit is open and the output equals (0).

The following table shows the possibilities of the effect of connecting and disconnecting the two switches on the light state (lighted \non-lighted) as the following symbols refer to:

A: The first switch    B: The second switch    L: light

<b>A</b>	<b>B</b>	<b>L</b>
<b>Off</b>	<b>Off</b>	<b>NON-LIGHTED</b>
<b>On</b>	<b>Off</b>	<b>LIGHTED</b>
<b>Off</b>	<b>On</b>	<b>LIGHTED</b>
<b>On</b>	<b>On</b>	<b>LIGHTED</b>

### The symbol of the logic OR gate:

The following symbol represents the logic OR gate (two binary inputs).

Study the symbol, and then discuss your notices with your teacher and your classmates.

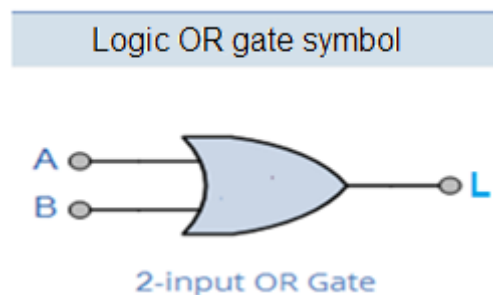

### From the previous figure, we can notice that:

- 1- A, B refer to the inputs of OR gate, where L refers to the output of the gate.
- 2- The input of each gate is at the left side of the code, and includes the values of all input possibilities, the input is represented as (binary numbers) 2 input (0, 1).
- 3- Output is shown on the right side as (binary numbers).

### Number of forms (possibilities):

Each logic gate has number of forms or possibilities, and it is calculated according to the number of logic gate inputs with the following law:

$$\mathbf{N = 2^n}$$

As N refers to the number of forms, as this law is previously studied in the first subject the Logic AND gate.

**Example:** OR gate (two binary inputs), its forms are calculated as:

$$N = 2^2 = 4$$

But if the OR gate that has three inputs, its forms or possibilities are:

$$N = 2^3 = 8$$

By the same method, you can calculate the forms or possibilities of any OR gate.

### **Truth Table:**

Truth table helps in explaining the logic OR gate behaviors according to the relation between inputs and output of the logic gate.

If the value of the two inputs (A, B) equals (0), output will not be found which means:

$$(L) = (0)$$

**Which means:** if the two conditions don't exist together, we can't get the output, which is represented on the electric figure that simulates the selecting OR gate.

The light is lighted when any condition of them or both of them exist together, and the value is (On).

## Notice:

- Any Input represents a condition, so, if the two conditions don't exist together in OR gate, we can't get the output.
- In OR gate the output ( $L$ ) = ( $\underline{1}$ ), when the input is (1) whether each of the two conditions (A, B) or both of them equal to the value (1).

**So, we can produce the truth table of the logic OR gate (the two binary inputs) as the following:**

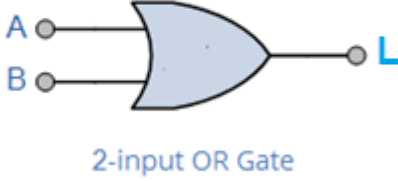
Symbol	Truth Table		
 <p>2-input OR Gate</p>	B	A	L
	0	0	0
	0	1	1
	1	0	1
	1	1	1

## The Boolean formula for the logic OR gate:

The next Boolean expression represents OR gate of the two inputs by the next formula:

$$Y=A+B$$

It is expressed as: The output Y equals A OR B.

This gate is called "Logical Addition".

**We can conclude the previous in the next table:**

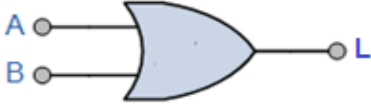
Notice	Representation on OR gate																		
Name of the gate	<b>OR</b>																		
The Logic symbol -standard- of the gate																			
Number of forms	<p>We can calculate number of forms or possibilities that forms Truth table of OR gate by the following law :</p> <p style="text-align: center;"><b><math>N = 2^n</math></b></p> <p style="text-align: center;"><b><math>N = 2^2 = 4</math></b></p>																		
Truth table	<table border="1" data-bbox="812 1055 1211 1426"> <thead> <tr> <th colspan="3">Truth Table</th> </tr> <tr> <th>B</th> <th>A</th> <th>L</th> </tr> </thead> <tbody> <tr> <td>0</td> <td>0</td> <td>0</td> </tr> <tr> <td>0</td> <td>1</td> <td>1</td> </tr> <tr> <td>1</td> <td>0</td> <td>1</td> </tr> <tr> <td>1</td> <td>1</td> <td>1</td> </tr> </tbody> </table>	Truth Table			B	A	L	0	0	0	0	1	1	1	0	1	1	1	1
Truth Table																			
B	A	L																	
0	0	0																	
0	1	1																	
1	0	1																	
1	1	1																	
The expression of The Boolean formula.	<p style="text-align: center;"><b><math>Y = A + B</math></b></p> <p>An expression of The boolean formula for the logic OR gate of the two inputs.</p>																		

## Activity (1)

"Truth table of the logic OR gate"

Activity book (p: 15)



## Fifth Subject

### Producing a project of the logic OR gate simulation



#### Learning outcomes:

At the end of this subject learner should have the ability to:

- Explain stages of producing a project of the logic gate (OR) simulation by using (VB.NET) language.
- Design the interface of the project by using Visual Studio.NET application.
- Explain the code that is used in a project of operating the logic gate OR simulation.
- Employ the code in the project implementation practically.

### The project purpose:

Producing a program that simulates the logic OR gate.

### Requirements of producing the project:

- 1- Providing the scientific background of the logic gate OR in terms of:  
Its concept, its truth table, and the Boolean formula of the logic gate, and that is what is studied before.
- 2- Selecting the programming language that you can use in producing the project and you can benefit from your previous experience in Visual Basic.NET language or PHP language.

### Stages of the project implementation:

- 1- Designing the user's interface of the project "Graphic User Interface" GUI, and determining appropriate Controls for each use to produce the project properly.
- 2- Adjusting the controls properties in the light of the necessary needs for the production of the project.
- 3- Writing the programming code.

### Stages of the project production:

#### Firstly: Designing the user's interface of the project:

You can design the user's interface of the project and put appropriate controls on it to achieve the purpose of (connecting- disconnecting) electric light switch simulation.

The following figure displays a proposal of the form window and necessary controls for producing the project.

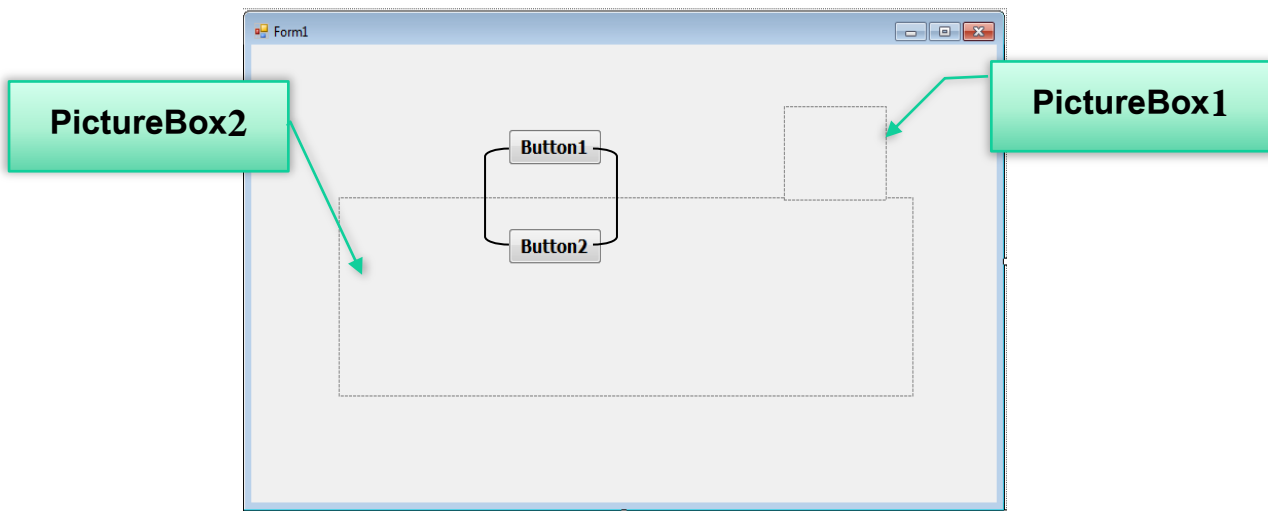

Take part with your classmates in studying the figure, and then conclude controls on the window, and its purpose. Save it in the specified table in exercise (1).

## Activity (1)

Designing the user interface of the project

Activity book (p:16)

By studying the previous figure, we can conclude controls on the form window and the purpose of each of them, and displaying them in the next table:

Controls	The purpose
Form1	The basic object, on which we put Controls that are used in the user's interface.
Button1	An object that is used in implementing a specific code when it is clicked.
Button2	An object that is used in implementing another code when it is clicked.
PictureBox1	An object that is used to display the light image.
PictureBox2	An object that is used to display the electrical circuit.

### **Secondly: The stage of design implementation and control adjusting:**

Through the application or the selected programming language of the project, (Visual Studio. NET), you can start inserting necessary Controls for producing the logic gate OR simulation, and adjust its properties as in the following activity:

## Activity (2)

Implementing a design of the user interface application (Visual Studio.Net)

Activity book (p:17)

### Thirdly: The stage of writing the programming code:

Before starting to write and implement the project code, try to guess the possible results of flowing or not flowing of the current in the circuit, there are four possibilities that we can display in the following table:

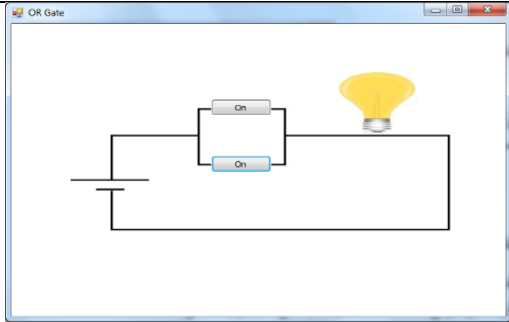
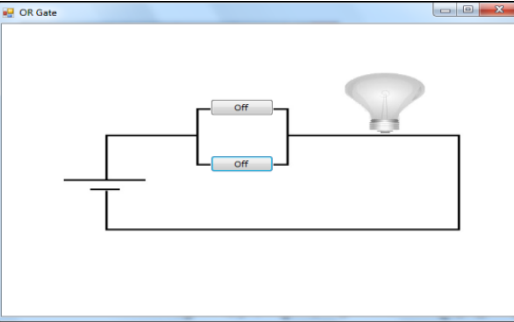
	
<ul style="list-style-type: none"> <li>• First switch state: <b>on</b></li> <li>• Second switch state: <b>on</b></li> <li>• Light image: <b>lighted</b></li> </ul>	<ul style="list-style-type: none"> <li>• First switch state: <b>off</b></li> <li>• Second switch state: <b>off</b></li> <li>• Light image: <b>non-lighted</b></li> </ul>

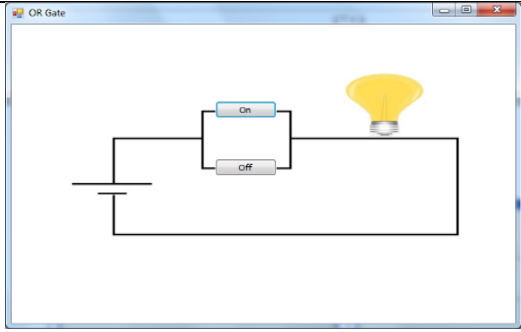
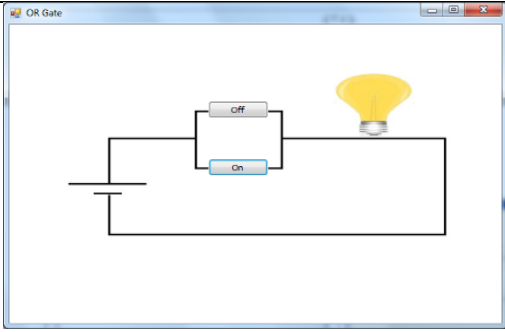
	
<ul style="list-style-type: none"> <li>• First switch state: <b>on</b></li> <li>• Second switch state: <b>off</b></li> <li>• Light image: <b>lighted</b></li> </ul>	<ul style="list-style-type: none"> <li>• First switch state: <b>off</b></li> <li>• Second switch state: <b>on</b></li> <li>• Light image: <b>lighted</b></li> </ul>
<p>From the previous table, we can conclude the following:</p> <ul style="list-style-type: none"> <li>• Switch state is changed between "On "and" Off" by clicking (Click) on the switch.</li> <li>• There are two images of the light in two separated files, (one of them is lighted and the other is non-lighted), which are shown on PictureBox1.</li> </ul>	

## The idea of the code is summarized in the following:

1. Selecting an object or more that is responsible for the code implementation, on the occurrence of a particular event.

In this project, we can write the code in the following objects:

- Form object in loading event form1\_load:

To show the non-lighted light image, the " circuit" image, and showing the state of the two switches "off".

- Button1 object:

When we press click, switch state is selected, and its state is changed between (Off, On).

Testing first and second switches state and changing the light image into the valid state that is appropriate to the two switches state.

- Button2 object:

When we press click, switch state is tested, and its state is changed between (Off, On).

Testing first and second switches state and changing the light image into the valid state that is appropriate to the two switches state.

### 2. Writing the code of each object from the three previous objects.

In producing a project of logic OR gate simulation, we will study and explain the used code through a particular code of the book , its operating effect is represented on Light state ,whether it is lighted or non-lighted according to the two switches state,

Whether it is "On "or "Off "after pressing Click on the two switches, through the following code:

Dear student, you can study and explain the displayed code in front of you with your teacher and classmates, which is divided into three parts to facilitate its study.

**Private Sub Form1\_Load(ByVal sender As Object, ByVal e As System.EventArgs) Handles Me.Load**

**Me.PictureBox1.Image = Image.FromFile("off.jpg")**

**Me.PictureBox2.Image = Image.FromFile("circuit.jpg")**

**Me.Button1.Text = "Off"**

**Me.Button2.Text = "Off"**

First part

**End Sub**

**Private Sub Button1\_Click(ByVal sender As System.Object, ByVal e As System.EventArgs) Handles Button1.Click**

**If Me.Button1.Text = "Off" Then**

**Me.Button1.Text = "On"**

**Me.PictureBox1.Image= Image.FromFile("on.jpg")**

**Else**

**Me.Button1.Text = "Off"**

**If Me.Button2.Text = "Off" Then**

**Me.PictureBox1.Image = Image.FromFile("off.jpg")**

**End If**

**End If**

**End Sub**

**Private Sub Button2\_Click(ByVal sender As System.Object, ByVal e As System.EventArgs) Handles Button2.Click**

**If Me.Button2.Text = "Off" Then**

**Me.Button2.Text = "On"**

**Me.PictureBox1.Image = Image.FromFile("on.jpg")**

**Else**

**Me.Button2.Text = "Off"**

**If Me.Button1.Text = "Off" Then**

**Me.PictureBox1.Image = Image.FromFile("off.jpg")**

**End If**

**End If**

**End Sub**

Second part

Third part



### Code explanation:

The first part "Adjust the default mode of electrical circuit"

```
Private Sub Form1_Load(ByVal sender As Object, ByVal e As System.EventArgs) Handles Me.Load
```

```
Me.PictureBox1.Image = Image.FromFile("off.jpg")
```

```
Me.PictureBox2.Image =
```

```
Image.FromFile("orcircuit.jpg")
```

```
Me.Button1.Text = "Off"
```

```
Me.Button2.Text = "Off"
```

```
End Sub
```

### **Its purpose:**

BPOs programming code of Form1 in Load, to implement the code during downloading the form window, as:

- The light image is specified non-lighted from "off.jpg" file to PictureBox1.Image.
- The electrical circuit is specified from "Circuit.jpg" file to PictureBox2.Image.
- Presenting Button1 & Button2 switches in "Off "position.

Dear students, you have the choice to adjust the previous properties through Properties window or adjust it programmatically.

The second part" possibilities of operating the first switch ".

```

Private Sub Button1_Click(ByVal sender As System.Object,
ByVal e As System.EventArgs) Handles Button1.Click
    If Me.Button1.Text = "Off" Then
        Me.Button1.Text = "On"
        Me.PictureBox1.Image = Image.FromFile("on.jpg")
    Else
        Me.Button1.Text = "Off"
        If Me.Button2.Text = "Off" Then
            Me.PictureBox1.Image = Image.FromFile("off.jpg")
        End If
    End If
End Sub

```

Diagram annotations: A callout '1' points to the procedure signature. A callout '2' points to the first If-Then-Else block. A callout '3' points to the nested If-Then-End If block.

### Explaining the code of each section in second part:

1. Code is implemented in this Procedure when we Click on Button1.
2. If the first switch Button1 is on Off state, its state is changed into On, and the lighted light image is displayed.

- But, if the first switch Button1 is on On state, its state is changed into Off, and testing the second switch state , if it is on Off state, this means that the two switches states are on Off state ,and the non-lighted light image is displayed.

## The third part: "possibilities of operating the second switch".

```

Private Sub Button2_Click(ByVal sender As System.Object,
ByVal e As System.EventArgs) Handles Button2.Click
    If Me.Button2.Text = "Off" Then
        Me.Button2.Text = "On"
        Me.PictureBox1.Image = Image.FromFile("on.jpg")
    Else
        Me.Button2.Text = "Off"
        If Me.Button1.Text = "Off" Then
            Me.PictureBox1.Image = Image.FromFile("off.jpg")
        End If
    End If
End Sub
    
```

## Explaining the code of each section in third part:

- Code is implemented in this action when we Click on Button2.
- If the second switch Button2 is on Off state, its state is changed into On, and the lighted light image is displayed.
- If the second switch Button2 is on On state, its state is changed into Off, and then testing the first switch state , if it is on Off state, this means that the two switches states are on Off state ,and the non-lighted light image is shown.

## Activity (3)

You can use the code in producing and implementing  
"The logic OR gate simulation project"

Procedure No (4)

Activity book (p:20)

### **Sixth Subject**

Producing a project of logic OR gate in PHP

language



### **Learning outcomes:**

**At the end of this subject, learner should have the ability to:**

- Explain stages of producing a project of logic gate OR in PHP language.
- Produce a project of the logic gate OR work simulation on the Internet browser screen in PHP language.
- Explain PHP code in implementing a project of logic gate OR simulation.
- Employ PHP code in producing a project.

### Requirements of the project implementation in PHP language:

- (1) Project implementation through Internet browser window depends on some basics of markup language HTML, Expression Web application and PHP language that is studied before.
- (2) Using Expression Web application to create a Static Web Page, to help you in designing the user's interface of the project, and displaying it on the browser window.

### Producing a project of logic OR gate simulation in PHP language passes through the following stages:

#### 1- Designing stage:

Dear student, you can design a web page from your own, which contains the possible controls of achieving the purpose, which is producing the project "logic OR gate simulation" and displaying it on the browser window.

#### 2- Stage of implementing the web page of the project:

Dear student, there are a lot of applications that you can use in adding controls on the browser window, as Expression Web, and through Toolbox, you can put necessary articles, titles and controls to implement designing the web page.

The next image shows a proposal of web page design that is displayed on the browser window, and its necessary controls of the project implementation.

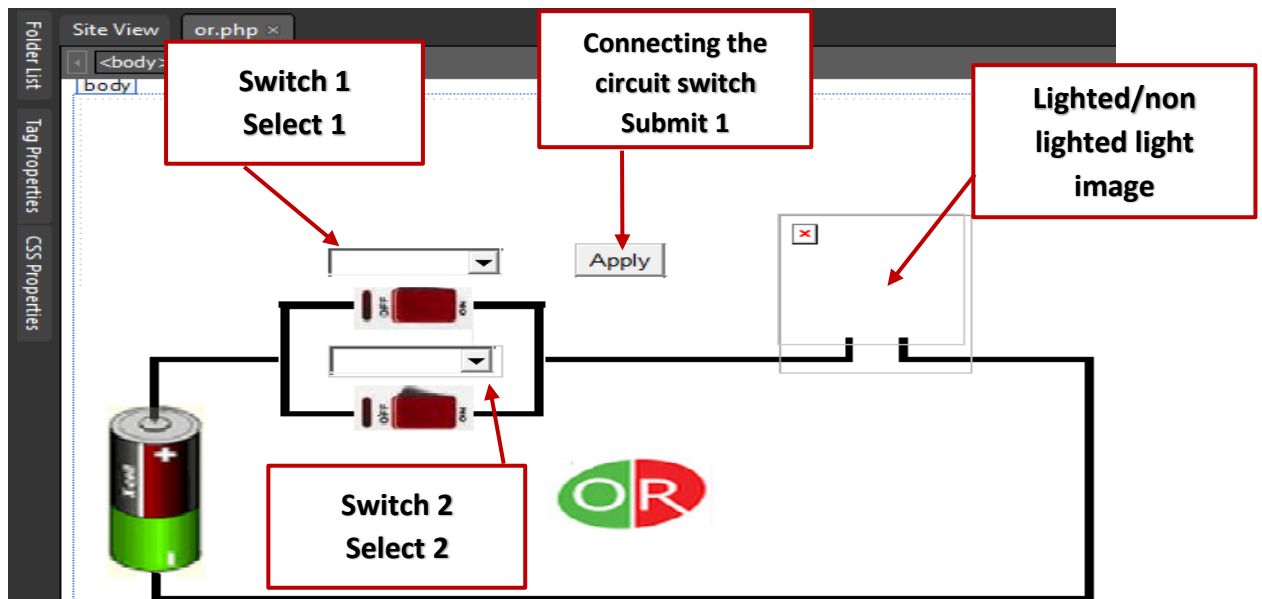

First and second switches states are selected, from the two Drop down lists, and by Clicking on submit1, the light image is shown, whether it is lighted or non-lighted according to the two switches states.

Study the previous figure, and discuss the expected possibilities of operating the logic OR circuit on the browser window with your teacher and classmates.

**From studying the previous figure, we can determine the possibilities of operating the logic circuit OR on the browser window.**

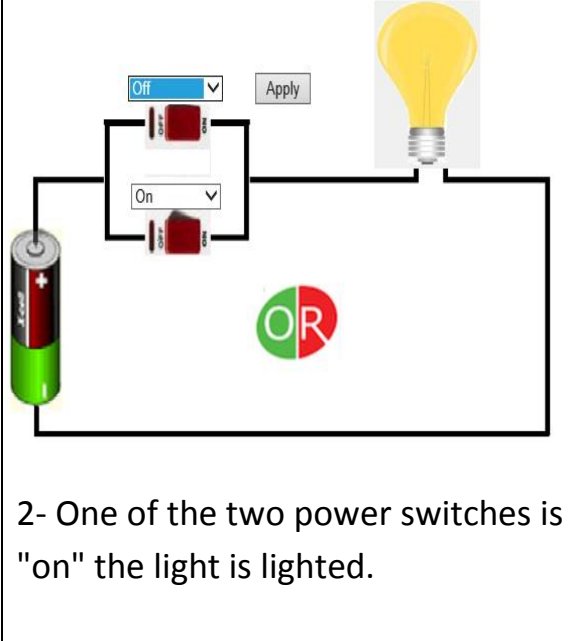
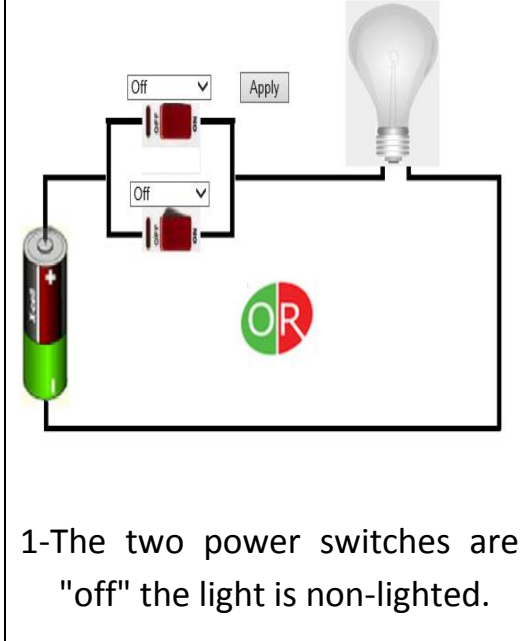
 <p>2- One of the two power switches is "on" the light is lighted.</p>	 <p>1-The two power switches are "off" the light is non-lighted.</p>
---	--

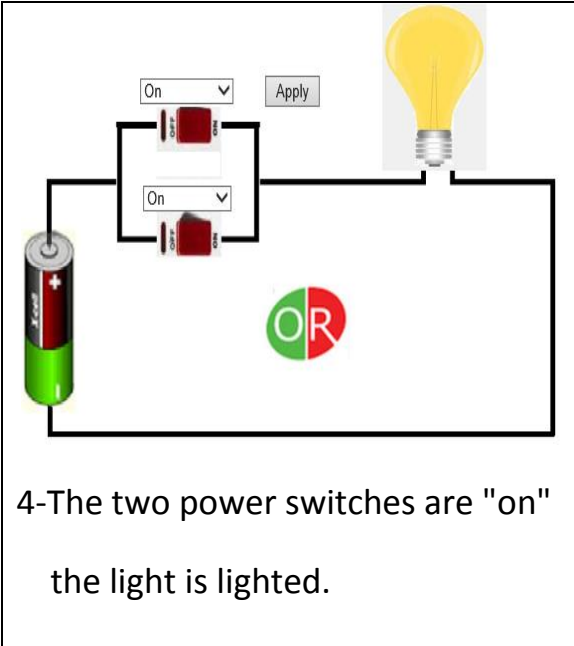
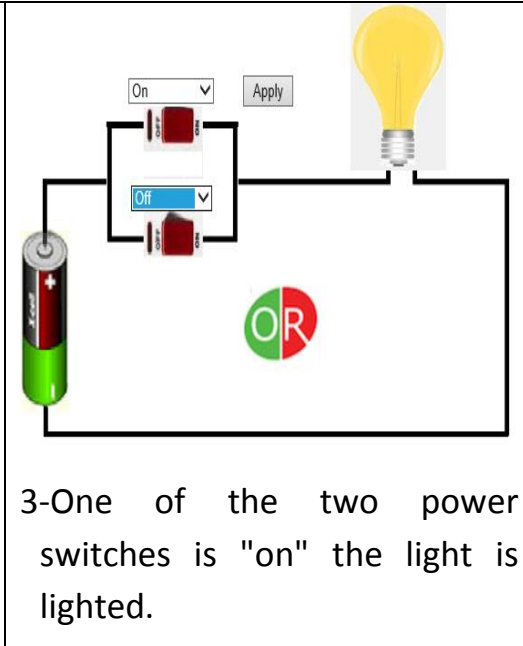
 <p>4-The two power switches are "on" the light is lighted.</p>	 <p>3-One of the two power switches is "on" the light is lighted.</p>
--	---



### 3- Stage of writing the programming code:

Dear students, you can employ the programming code in PHP language, in treating data of the web page and put the Controls objects on the model window of the interface application of the project. Thus through your implementation of the following activity in the activities book, as the previous study of explaining the code of the logic gate AND, under the supervision of your teacher.

### Activity (1)

Employing PHP code in producing a project that  
simulates the logic OR gate

Activity book (22)

## Seventh Subject

### The logic NOT gate



### Learning outcomes:

At the end of this subject, learners should have the ability to:

- Explain the logic NOT gate.
- Discuss the code of the logic NOT gate with his classmates.
- Conclude Truth Table of NOT gate.

## The logic gate NOT:

It is called the Inverter Gate, it is the gate that has only one input and one output, and the inverter changes the logic value of the input into its reflection, so if the value of the input is (1), the value of the output is (0) and if the value of the input is (0) the value of the output is (1).

The NOT gate is represented electrically with only one switch (A) as the gate input, and the light (L) represents the gate output, as what is shown in the following simulating figure of the Inverter Gate NOT:

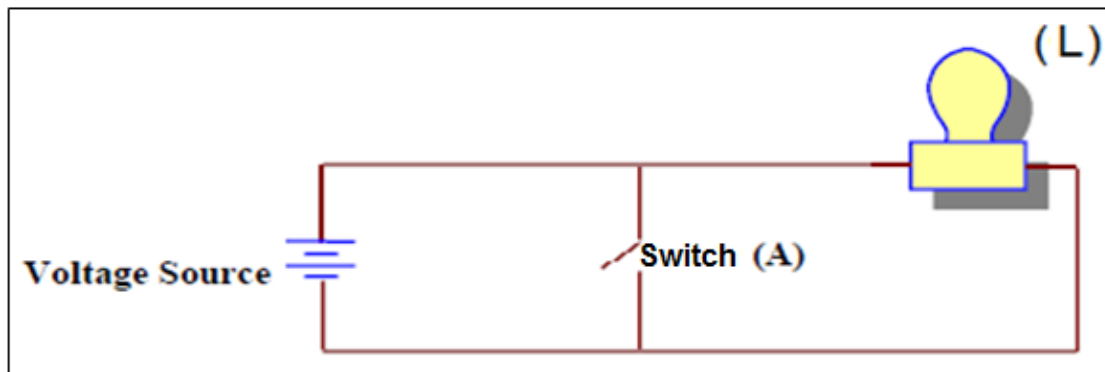

**The simulating figure of the Inverter NOT gate**

Study the previous figure of the selecting NOT gate simulation, describe it, conclude the relationship among its components, and discuss the results with your classmates and teachers.

From the previous simulating figure of the Inverter NOT Gate, we can conclude the possibilities of the effect of opening or shutting the switch on Light state, and representing it on the following table:

Assume A: switch state      L: light.

**Table shows the effect of opening or shutting the switch on the Light:**

<b>A</b>	<b>L</b>
<b>OFF</b>	<b>Lighted</b>
<b>ON</b>	<b>Non-lighted</b>

- From the previous table, we can conclude that the light is lighted only when the switch is separated and be in Off state.

### **The symbol of NOT gate:**

The logic gate symbol of NOT gate is presented as:

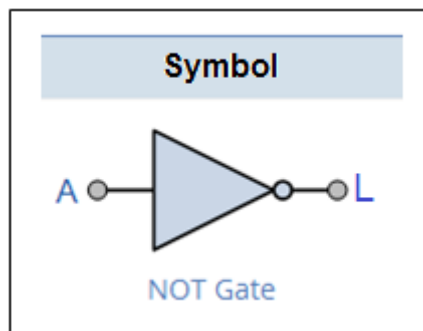

**The logic gate symbol of NOT gate**

As A: refers to the input of logic gate NOT, and L: refers to its output.

We can calculate the number of forms (possibilities) through the following law:

$$N = 2^n$$

As N: refers to the number of forms, and (2) refers to the binary system base that we use as the input gate value (0, 1) but n refers to the number of gate inputs.

The NOT gate has only one input (single), so, its forms number is:

$$N = 2^1 = 2$$

### Truth Table:

You can prepare the truth table of the logic NOT gate, to express the input in a Binary value as the following:

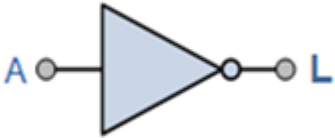
Symbol	Truth Table	
 <p>NOT Gate</p>	A	Q
	0	1
	1	0

Discuss the previous table with your teacher and classmates.

From the previous table, it is clear that:

- Any input represents one condition, so, if the condition exists in the logic NOT gate, the result will be the absence of the output.
- In NOT gate the output = (1) when the input = (0).

### The Boolean formula of the Logic gate NOT:

The Boolean expression that represents NOT gate is expressed by the following formula.

$$Y = \bar{A}$$

**It is said:**

**The output Y equals NOT A**

We can summarize the above in the following table:

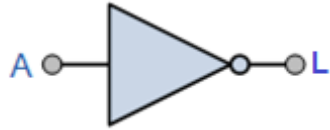
Statement	Representation at the NOT gate
Gate name	<b>NOT</b>
Logic symbol standard of the gate	
Number of forms	Number of forms or possibilities of the truth table is calculated by the following law  $N = 2^n$  $N = 2^1 = 2$

Truth table	<table border="1"><thead><tr><th colspan="2">Truth Table</th></tr><tr><th>A</th><th>Q</th></tr></thead><tbody><tr><td>0</td><td>1</td></tr><tr><td>1</td><td>0</td></tr></tbody></table>	Truth Table		A	Q	0	1	1	0
Truth Table									
A	Q								
0	1								
1	0								
The Boolean formula of the logic NOT gate.	$\bar{Y} = A$								

## Practice (1)

Truth table of the logic NOT gate

Activity book

Page (29).

### **Eighth Subject**

**A project of the logic NOT gate simulation.**



### **Learning outcomes:**

**At the end of this subject, learner should have the ability to:**

- Recognize the stages of a project of logic NOT gates simulation by using VB.NET language.
- Implement the user's interface design of a project of logic gates NOT simulation by using Visual Studio .NET application and one of the graphic programs.
- Explain the code that is used in a project of operating the logic NOT gate simulation.
- Employ the code that is used in the project implementation practically.



### **The project purpose:**

Producing a program that simulates the logic NOT gate.

### **Requirements of producing the project:**

- 1- 1-Providing the scientific background of the logic gate NOT In terms of its concept, its truth table, and the Boolean formula of the gate, and that what is previously studied.
- 2- 2-Providing the experience in coding languages that you can use in producing the project and you can benefit from your previous experience in Visual Basic.NET language.

### **Stages of the project implementation:**

- 1- Designing the user's interface of the project "Graphic User Interface" GUI, and determining appropriate Controls for each use to produce the project properly.
- 2- Setting the Controls properties in the light of the necessary needs for producing the project.
- 3- Writing the programming code.

## Stages of the project production

### Firstly: designing stage:

The following figure is the proposed model window and its necessary Controls of producing the project:

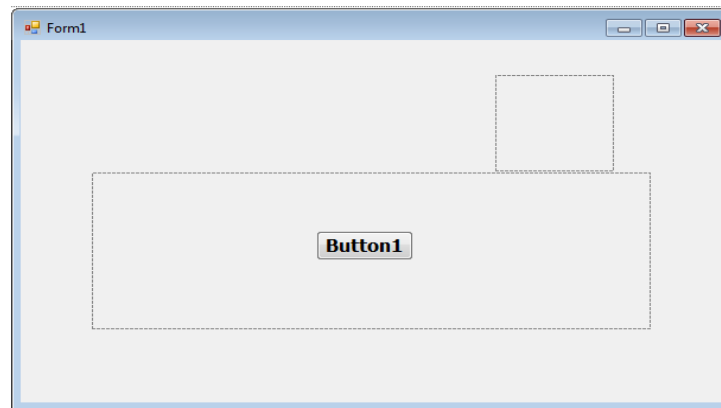

(Employ one of the graphic programs in designing the circuit image and the lighted and non-lighted light images).

## Practice (1)

Designing the user interface by using  
(Visual Studio.NET)

Activity book Page (30)

## Secondly: Implementation stage:

Use the selected application or coding language in starting inserting necessary Controls to implement the form design of the project of the logic NOT gate simulation.

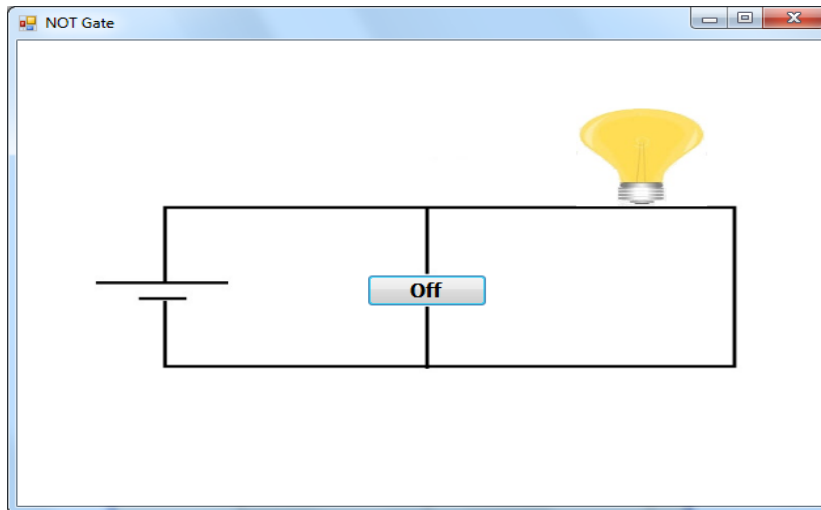

## Practice (2)

Designing the user interface of the project

Activity book Page (28:31)

## Thirdly: stage of writing programming code:

Before starting writing the project code, try to predict the possible results of the relation between the input and the output that help you in the project code implementation, which is about the following possibilities:

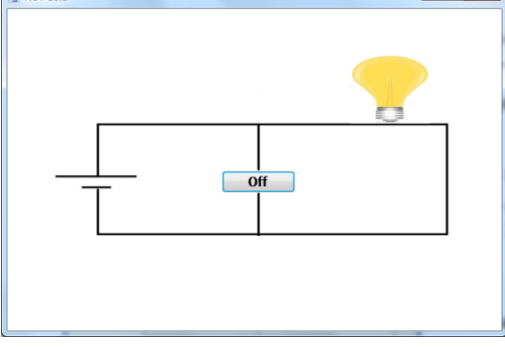
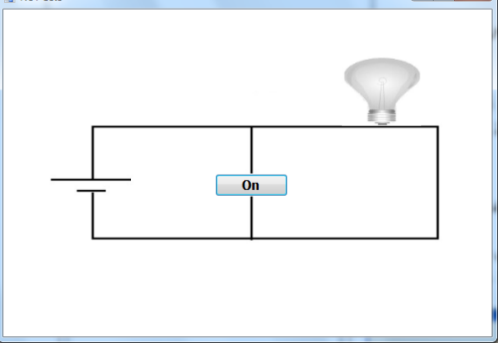
	
<ul style="list-style-type: none"> <li>- Switch state: <b>Off</b></li> <li>- Light image: <b>lighted</b></li> </ul>	<ul style="list-style-type: none"> <li>- Switch state: <b>On</b></li> <li>- Light image: <b>non-lighted</b></li> </ul>

## The idea of the code is summarized in the following:

(1) Determining the object (or more) that is responsible for the code implementation upon the occurrence of a particular event on it, in this project ,we can write the code in the following objects:

- **Object model in Form\_Load.**

To show the non-lighted light and the circuit images and showing the switch state " On".

- **Button1:**

To select switch state, which is On or Off and its effect on changing the light image into the valid appropriate state to the operating switch state in view of the truth table of the logic NOT gate.

(2) Writing the code of the two project objects:

Now, we can study and explain the code that is used in the project of logic NOT gate simulation, through its code, its effect on switch state whether it is lighted or non-lighted is shown according to the operating switch state which is On or Off when it is Clicked, and this is done through the following code:

Part 1

```
Private Sub Form1_Load(ByVal sender As Object, ByVal e As System.EventArgs) Handles Me.Load  
    Me.PictureBox1.Image = Image.FromFile("off.jpg")  
    Me.PictureBox2.Image= Image.FromFile("notcircuit.jpg")  
    Me.Button1.Text = "On"  
End Sub
```

Part 2

```
Private Sub Button1_Click(ByVal sender As System.Object, ByVal e As System.EventArgs) Handles Button1.Click  
    If Button1.Text = "Off" Then  
        Button1.Text = "On"  
        Me.PictureBox1.Image = Image.FromFile("off.jpg")  
    Else  
        Button1.Text = "Off"  
        Me.PictureBox1.Image = Image.FromFile("on.jpg")  
    End If  
End Sub
```

- **Discuss the previous code explanation with your teacher and classmates, in view of your previous studied projects.**

## Practices (3),(4)

"Study of the code that is used in production and implementation of the project simulation of operating the logic NOT gate"

Activity book Page (33:35)

### **Ninth Subject**

**Producing a project of the logic NOT  
gate in PHP language**



### **Learning outcomes:**

**At the end of this subject learner should have the ability to:**

- Conclude stages of logic gate NOT simulation project in PHP language.
- Implement the user's interface design of logic gate NOT simulation project by using Expression Web application.
- Explain the code that is used in logic gate NOT simulation project.
- Employ PHP code practically in producing the project.

### **Requirements of the project implementation in PHP language:**

- (1) Implementing the project through the Internet browser screen depends on some basics of HTML coding language, Expression Web application and PHP language.
- (2) Using Expression Web application to create a Static Web Page in order to help you in designing the user's interface of the project and displaying it on the browser screen.

### **Producing a project of the logic NOT gate simulation (by using PHP language) passes through the following stages:**

#### **1- Designing stage:**

Dear student, you can design a web page that has the appropriate controls to achieve the purpose of producing a project of the logic NOT gate simulation, in order to display it on the Internet browser window.

#### **2- The stage of implementing the web page of the project:**

Dear student, there are a lot of applications that you can use to add Controls on the browser window, as Expression Web application , as you can add necessary text, titles and controls to implement a design of the web page through Control ToolBox.

**The following figure show a proposal of a web page design which is displayed on internet browser screen, and its necessary Controls of producing the project.**



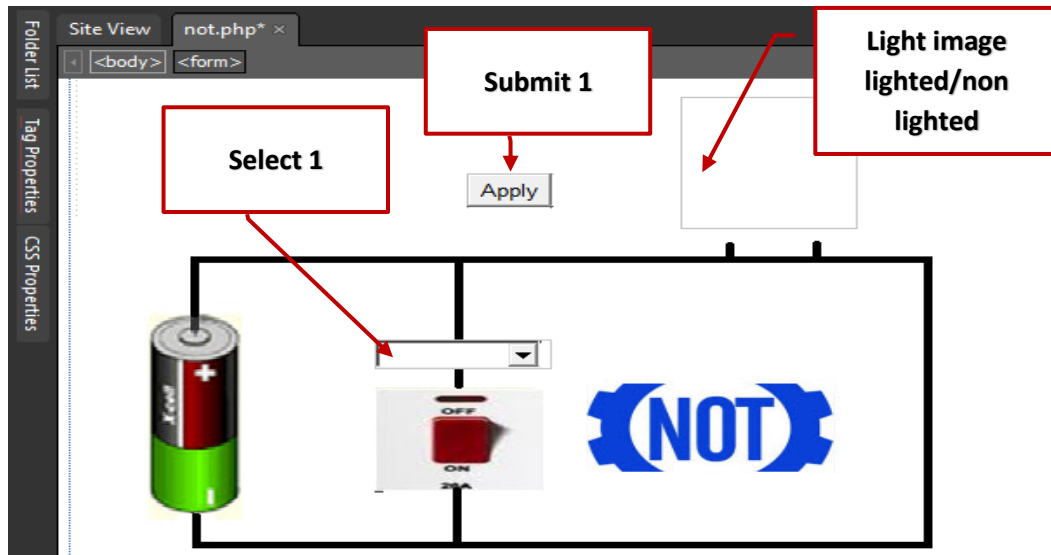

Operating switch state is selected from Select 1 and by pressing on connect circuit switch, light image is shown whether it is lighted or non-lighted at the opposite of selecting state.

### The possibilities of logic NOT circuit on the internet browser window.

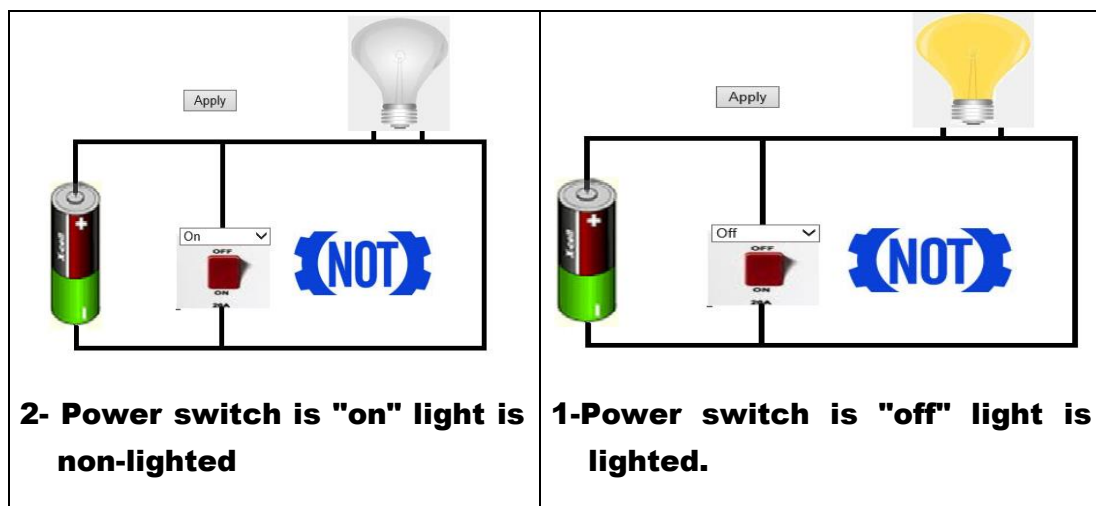

You can practice the following activity from Activities and exercises book, in view of the projects of the logic circuits which are previously studied , and thus through your co-operation with your classmates and your teacher.

### Activity (1)

"Employing PHP code in producing a project of the logic NOT gate simulation on the web page"

Activity book Page (37).

### Tenth Subject

Employing logic gates in life-taking decisions



#### Learning outcomes:

At the end of this subject learner should have the ability to:

- Examine the problem depending on the possible inputs and required outputs.
- Make use of logical thinking in the problem solution.
- Select the appropriate logic gate to solve the problem.
- Employ the logic gates in life – taking decisions.

Do you know, dear students that the behavior you can precede in life-taking decisions, is enormously similar to the logic gate idea:

As, taking any decision depends on the possible inputs and required outputs, and selections depend on the logic gate type that is appropriate to decision kind that is taken.

We hope to ensure on the importance of the logic gates and clarify it as a method of thinking and a life style that we can practice and use unconsciously in taking any decision , especially when this decision depends on more than one condition or one input.

### **Example:**

We have an example that shows employing the logic gate in taking decision:

The ministry of Housing and constructing societies declares about the beginning of booking in youth society project, and to be accepted, you have to be older than 25 years old and to be married.

By examining the declaration of the competition we reached that:

- The required output is accepting the applicant form of housing.
- Number of conditions (outputs) is two conditions:
  - Age is to be older than 25.
  - The applicant marital status is to be married.
- The two conditions have to be existed together in order to reach the application to acceptance stage.

- And by proceeding the logical thinking manner, we find that the only logic gate that is appropriate to this state is AND gate, as, it has one output and two obligatory inputs.
- If the two inputs (conditions) exist together, the decision in this state is to accept the application.
- We can express this state by the following table :

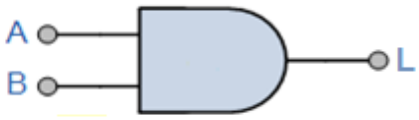
Question	Answer
(1) Name of the logic gate that represent the state	<b>AND</b>
(2) The logic gate symbol that represents the state.  <b>As:</b> A: Age is to be older than 25 years old.  B: The applicant marital status is to be married.  L: Acceptance of the application (the output).	
(3) The Boolean formula of the gate.	<b><math>L = A \cdot B</math></b>

(4) Truth table of the logic gate that represents the state.

As we find that the only state that produces the output is the existence of the two conditions A, B together, which makes the application accepted.

Truth Table		
B	A	L
0	0	0
0	1	0
1	0	0
1	1	1

As the previous, you can study the applications of the following activity with your classmates and with your teacher's help.

## Activity (1)

Applications on "employing  
Logic gates in life taking-decisions"

Activity book Page (41)

### Book conclusion

Dear students:

By the end of the second unit, third grade book of **INFORMATION& COMMUNICATION TECHNOLOGY** is finished through producing the suggested programming projects, which affords new visions of producing other projects of your design by using possible programs and applications, especially Free Source.

We hope to be succeeded to participate in enrichment of your knowledge and learning, through affording the necessary programming code in projects implementation, which represents a base to develop your learning in writing a code completely or update the available code to be suitable for your needs.

**GOD BLESSES YOU.**

**STAFF**